

MINIMUM CLEARANCE

FRONT	1.5 ft.
TOP	12 in.
REAR	1.5 ft.
LEFT	2 ft.
RIGHT	2 ft.

FRONT

RIGHT SIDE

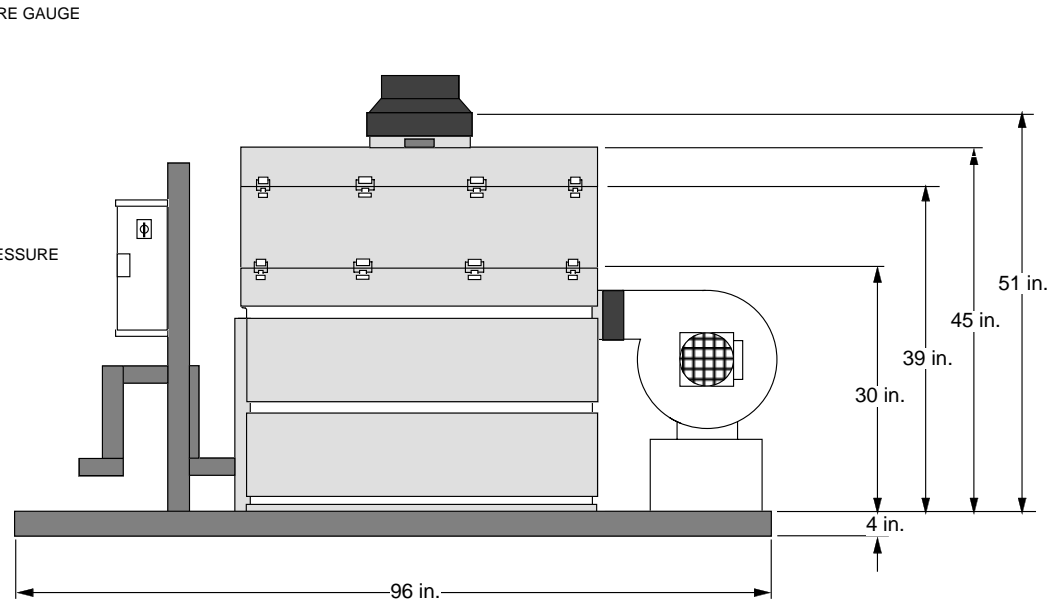
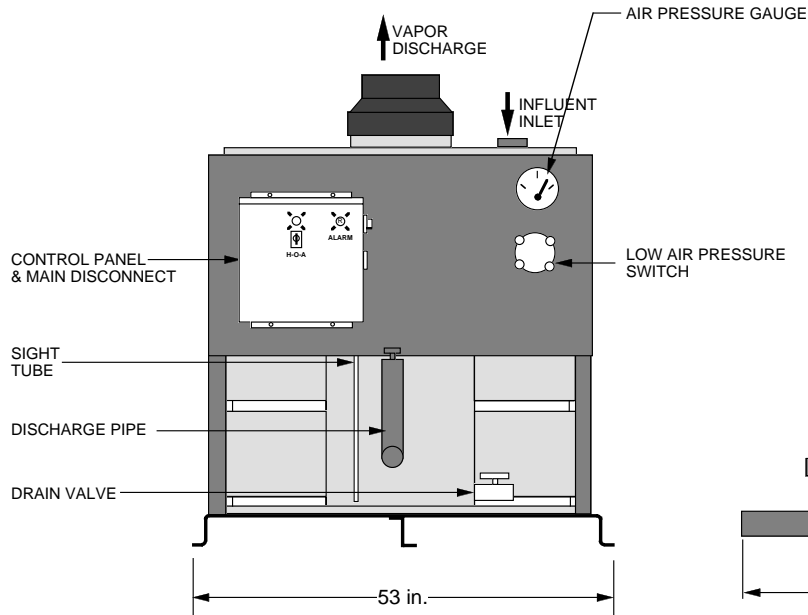

BASIC SYSTEM

- ✓ SUMP TANK
- ✓ STRIPPER TRAYS
- ✓ BLOWER
- ✓ MIST ELIMINATOR
- ✓ PIPING
- ✓ SPRAY NOZZLE
- ✓ WATER LEVEL SIGHT TUBE
- ✓ GASKETS
- ✓ LATCHES

OPTIONAL ITEMS

- ✓ SKID & STANCHION
- ✓ AIR PRESSURE GAUGE
- ✓ GRAVITY DISCHARGE PIPING
- DISCHARGE PUMP
- FEED PUMP
- ADDITIONAL BLOWER
- EXPLOSION-PROOF MOTOR(S)
- LOCAL DISCONNECT NEMA 7
- ✓ CONTROL PANEL
- ✓ MAIN DISCONNECT SWITCH
- I.S. COMPONENTS/REMOTE MOUNT
- ✓ INTERMITTENT OPERATION
- STROBE LIGHT
- ALARM HORN
- POWER LAPSE INDICATOR
- ✓ LOW AIR PRESSURE ALARM SWITCH(ES)
- ✓ HIGH WATER LEVEL ALARM SWITCH
- DISCHARGE PUMP LEVEL SWITCH
- WATER PRESSURE GAUGE(S)
- DIGITAL WATER FLOW INDICATOR
- AIR FLOW METER
- TEMPERATURE GAUGE(S)
- LINE SAMPLING PORT(S)
- AIR BLOWER SILENCER
- WASHER WAND
- AUTO DIALER

NOTE: THIS DRAWING IS REPRESENTATIVE OF A STANDARD SHALLOWTRAY CONFIGURATION, AND IS NOT INTENDED FOR ENGINEERING DESIGN OR LAYOUT. ACTUAL ARRANGEMENT AND DIMENSIONS MAY VARY DEPENDING ON BLOWER SELECTION OR OTHER ACCESSORIES. PLEASE CONTACT NEEP FOR DETAILED DESIGN INFORMATION.

POWER: 3Ø, 460 Volts, 3 WIRE + GROUND 60 Hz

*CONSULT N.E.E.P. FOR AMPACITIES AND OTHER VOLTAGE OPTIONS

STRIPPER CONSTRUCTION:

ROTATIONALLY MOLDED (~43°Ø)
LOW DENSITY POLYETHYLENE (LDPE)

CONNECTION INFORMATION

ITEM	SIZE
GRAVITY DISCHARGE	3"Ø SOCKET, PVC80
DISCHARGE PUMP	1 1/4" Ø FNPT
WATER INLET	1-1/4" Ø FNPT
AIR EXHAUST NOZZLE	8"Ø STUB W/8"x6" CPLG

	NORTH EAST ENVIRONMENTAL PRODUCTS, INC. 7 COMMERCE AVENUE WEST LEBANON, NEW HAMPSHIRE 03784 PHONE: 603-298-7061 FAX: 603-298-7063 http://www.neepsystems.com		
	DRAWING NAME: © 2002 NEEP ShallowTray® Model 2311-P		
TOLERANCES UNLESS OTHERWISE SPECIFIED: ± 1 INCH <small>8790</small>	DRAWING #: Proposal #Typical		
DRAWN: DCS	CUSTOMER: NEEPSYSTEMS.com		
DATE: 01/25/02	SCALE: NTS	SIZE: A	SHEET: 1 OF 1