

**MINIMUM CLEARANCE**

FRONT	1.5 ft.
TOP	12 in.
REAR	1.5 ft.
LEFT	2 ft.
RIGHT	2 ft.

**FRONT**

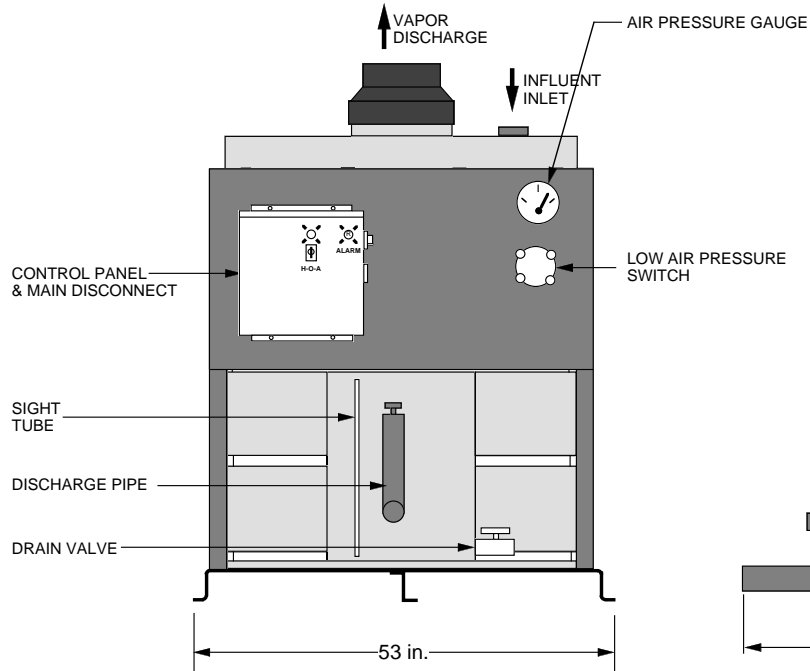

**RIGHT SIDE**

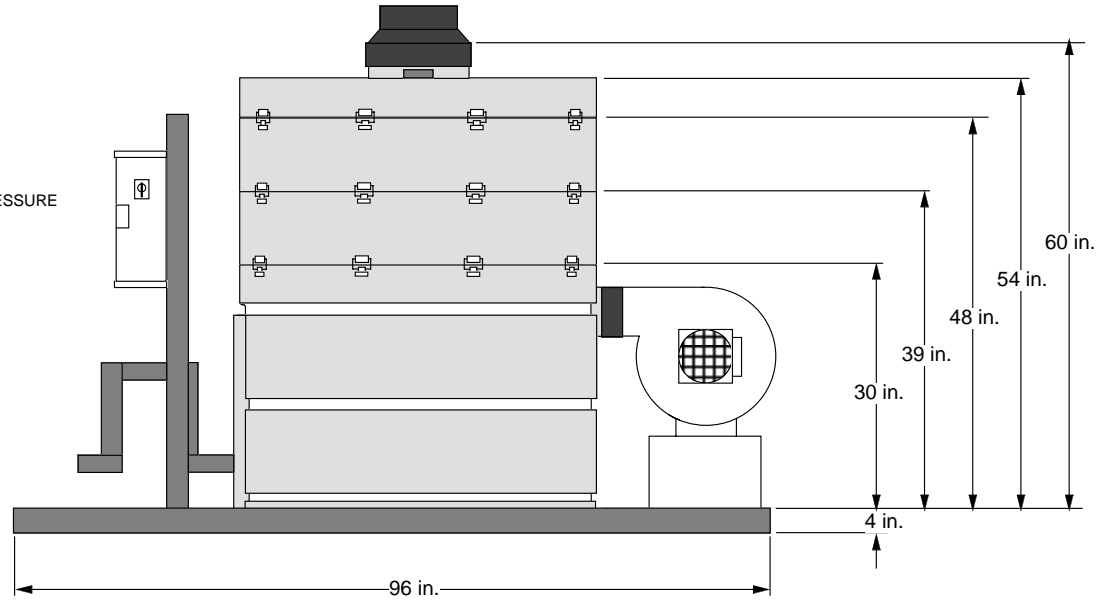

**BASIC SYSTEM**

- ✓ SUMP TANK
- ✓ STRIPPER TRAYS
- ✓ BLOWER
- ✓ MIST ELIMINATOR
- ✓ PIPING
- ✓ SPRAY NOZZLE
- ✓ WATER LEVEL SIGHT TUBE
- ✓ GASKETS
- ✓ LATCHES

**OPTIONAL ITEMS**

- ✓ SKID & STANCHION
- ✓ AIR PRESSURE GAUGE
- ✓ GRAVITY DISCHARGE PIPING
- DISCHARGE PUMP
- FEED PUMP
- ADDITIONAL BLOWER
- EXPLOSION-PROOF MOTOR(S)
- BLOWER START/STOP PANEL
- ✓ CONTROL PANEL
- ✓ MAIN DISCONNECT SWITCH
- I.S. COMPONENTS/REMOTE MOUNT
- ✓ INTERMITTENT OPERATION
- STROBE LIGHT
- ALARM HORN
- POWER LAPSE INDICATOR
- ✓ LOW AIR PRESSURE ALARM SWITCH(ES)
- ✓ HIGH WATER LEVEL ALARM SWITCH
- DISCHARGE PUMP LEVEL SWITCH
- WATER PRESSURE GAUGE(S)
- DIGITAL WATER FLOW INDICATOR
- AIR FLOW METER
- TEMPERATURE GAUGE(S)
- LINE SAMPLING PORTS
- AIR BLOWER SILENCER
- WASHER WAND
- AUTO DIALER

**NOTE:** THIS DRAWING IS REPRESENTATIVE OF A STANDARD SHALLOWTRAY CONFIGURATION, AND IS NOT INTENDED FOR ENGINEERING DESIGN OR LAYOUT. ACTUAL ARRANGEMENT AND DIMENSIONS MAY VARY DEPENDING ON BLOWER SELECTION OR OTHER ACCESSORIES. PLEASE CONTACT NEEP FOR DETAILED DESIGN INFORMATION.

**CONNECTION INFORMATION**

ITEM	SIZE
GRAVITY DISCHARGE	3"Ø SOCKET, PVC80
DISCHARGE PUMP	1 1/4"Ø FNPT
WATER INLET	1-1/4"Ø FNPT
AIR EXHAUST NOZZLE	8"Ø STUB W/8"x6" CPLG

**POWER:** 3Ø, 460 Volts, 3 WIRE + GROUND 60 Hz

\*CONSULT N.E.E.P. FOR AMPACITIES AND OTHER VOLTAGE OPTIONS

**STRIPPER CONSTRUCTION:**

ROTATIONALLY MOLDED (~43"Ø)  
LOW DENSITY POLYETHYLENE (LDPE)

	NORTH EAST ENVIRONMENTAL PRODUCTS, INC. 7 COMMERCE AVENUE WEST LEBANON, NEW HAMPSHIRE 03784 PHONE: 603-298-7061 FAX: 603-298-7063 <a href="http://www.neepsystems.com">http://www.neepsystems.com</a>		
	DRAWING NAME: <span style="float: right;">© 2002 NEEP</span> <b>ShallowTray® Model 2321-P</b>		
TOLERANCES UNLESS OTHERWISE SPECIFIED: ± 1 INCH <small>8pts</small>	DRAWING #: <b>Proposal #Typical</b>		
DRAWN: <b>DCS</b>	CUSTOMER: <b>NEEPSYSTEMS.com</b>		
DATE: <b>03/29/02</b>	SCALE: NTS	SIZE: A	SHEET: 1 OF 1