

MINIMUM CLEARANCE

FRONT	1.5 ft.
TOP	12 in.
REAR	N/A
LEFT	6.5 ft.
RIGHT	6.5 ft.

FRONT

RIGHT SIDE

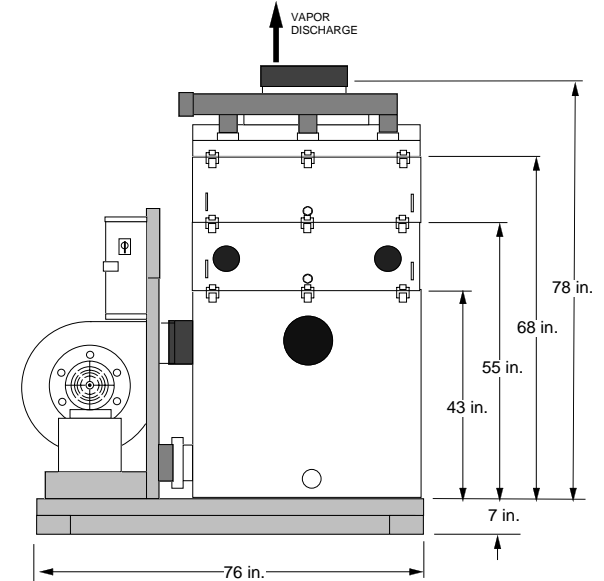
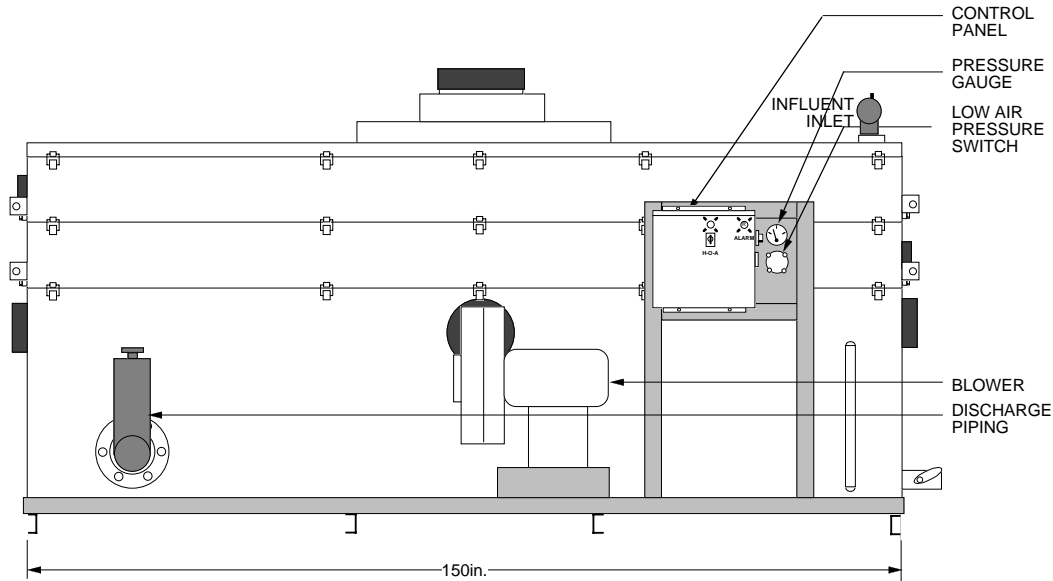

OPTIONAL ITEMS

- ✓ SKID & STANCHION
- ✓ AIR PRESSURE GAUGE
- ✓ GRAVITY DISCHARGE PIPING
- DISCHARGE PUMP
- FEED PUMP
- ADDITIONAL BLOWER
- EXPLOSION-PROOF MOTORS
- LOCAL DISCONNECT NEMA 7
- ✓ CONTROL PANEL
- ✓ MAIN DISCONNECT SWITCH
- I.S. COMPONENTS/REMOTE MOUNT
- ✓ INTERMITTENT OPERATION
- STROBE LIGHT
- ALARM HORN
- POWER LAMPSE INDICATOR
- ✓ LOW AIR PRESSURE ALARM SWITCH(ES)
- ✓ HIGH WATER LEVEL ALARM SWITCH
- DISCHARGE PUMP LEVEL SWITCH
- WATER PRESSURE GAUGE(S)
- DIGITAL WATER FLOW INDICATOR
- AIR FLOW METER
- TEMPERATURE GAUGE(S)
- LINE SAMPLING PORT(S)
- AIR BLOWER SILENCER
- ✓ WASHER WAND
- AUTO DIALER

BASIC SYSTEM

- ✓ SUMP TANK
- ✓ STRIPPER TRAYS
- ✓ BLOWER
- ✓ MIST ELIMINATOR
- ✓ PIPING
- ✓ SPRAY NOZZLE
- ✓ WATER LEVEL SIGHT TUBE
- ✓ GASKETS
- ✓ LATCHES

NOTE: THIS DRAWING IS REPRESENTATIVE OF A STANDARD SHALLOWTRAY CONFIGURATION, AND IS NOT INTENDED FOR ENGINEERING DESIGN OR LAYOUT. ACTUAL ARRANGEMENT AND DIMENSIONS MAY VARY DEPENDING ON BLOWER SELECTION OR OTHER ACCESSORIES. PLEASE CONTACT NEEP FOR DETAILED DESIGN INFORMATION.

CONNECTION INFORMATION

ITEM	SIZE
GRAVITY DISCHARGE	8"Ø SOCKET, PVC80
DISCHARGE PUMP	3"Ø FNPT
WATER INLET	4"Ø FNPT
AIR EXHAUST NOZZLE	16"Ø STUB w/16" CPLG

POWER: 3Ø, 460 volt, 3 WIRE + GROUND, 60 Hz

*CONSULT N.E.E.P. FOR AMPCITIES AND OTHER VOLTAGE OPTIONS

STRIPPER CONSTRUCTION:

304L STAINLESS STEEL



NORTH EAST ENVIRONMENTAL PRODUCTS, INC.
 7 COMMERCE AVENUE
 WEST LEBANON, NEW HAMPSHIRE 03784
 PHONE: 603-298-7061 FAX: 603-298-7063
 www.neepsystems.com

TOLERANCES UNLESS OTHERWISE SPECIFIED: ± 1 INCH	DRAWING NAME: ShallowTray® Model 31221		
	DRAWING #: Proposal #Typical		
DRAWN: DCS	CUSTOMER: NEEPSYSTEMS.com		
DATE: 10/15/02	SCALE: NTS	SIZE: A	SHEET: 1 OF: 1